

Vendor A – Cloud Manufacturer  
 Primary provider of IAAS and/or  
 Primary provider of PAAS and/or  
 Primary provider of SAAS and/or  
 Primary provider of XAAS

Vendor B – Cloud Manufacturer  
 Primary provider of IAAS and/or  
 Primary provider of PAAS and/or  
 Primary provider of SAAS and/or  
 Primary provider of XAAS

Vendor C – Cloud Manufacturer  
 Vendor adds value to primary cloud providers by combining them in configurations need by the end user

Vendor A as IAAS subcontractor

Vendor B as SAAS subcontractor

Vendor X as Design subcontractor

Vendor Y as security subcontractor

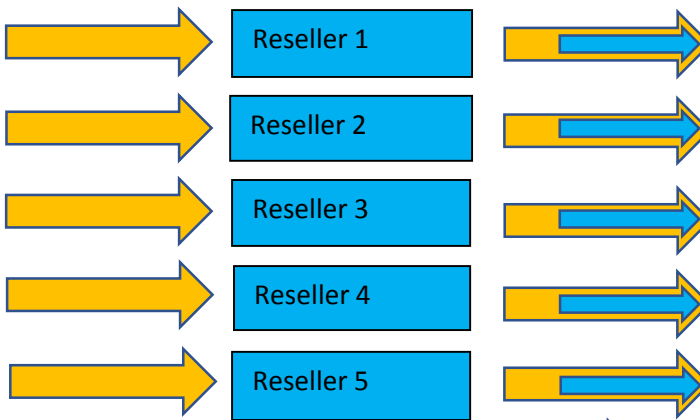
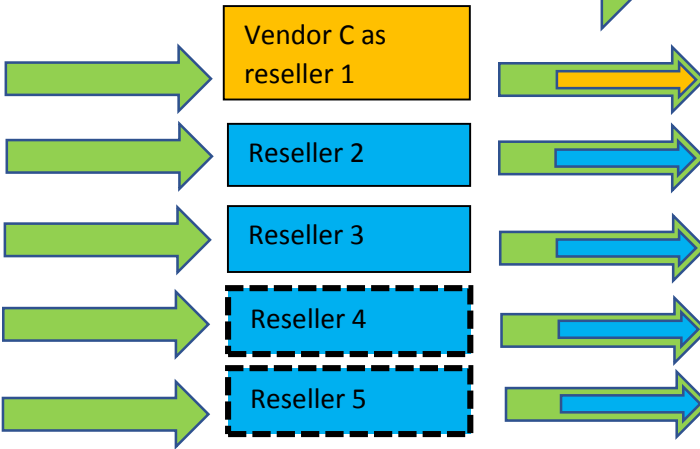
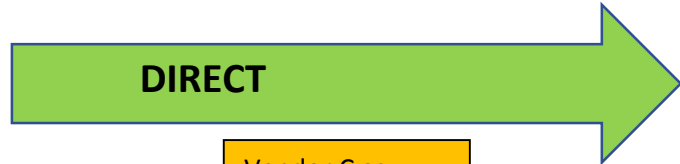
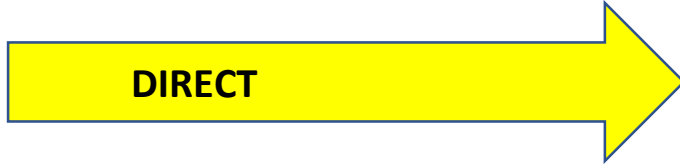

Mini-bids can be exclusive to one manufacturer in they have 5 or more resellers otherwise users must solicit all vendors with similar services

# End User

## LOT 3: CLOUD SERVICES Manufacturer Combinations and Responsibility

This chart is to illustrate some, but not all, possible combinations of Cloud manufacturers participating in Lot 3 of the umbrella contract. The Periodic Recruitment Solicitation encourages all of these possibilities.

On the image, the vendor responsible to the end user can be tracked by matching the colored arrows to the like-colored vendor, reseller or subcontractor.